

Fig1

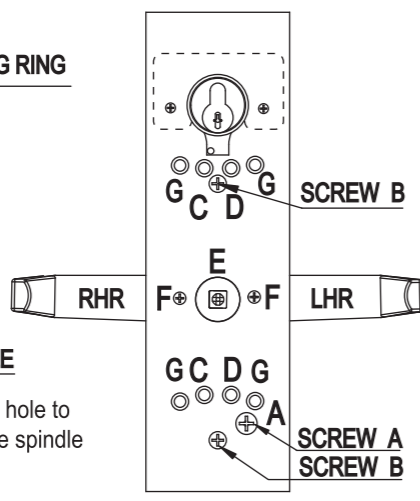

Fig2

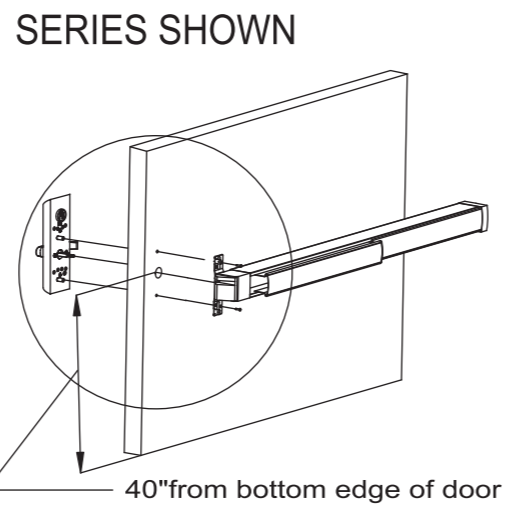

Fig3

T840M14SS Series LEVER ESCUTCHEON TRIM

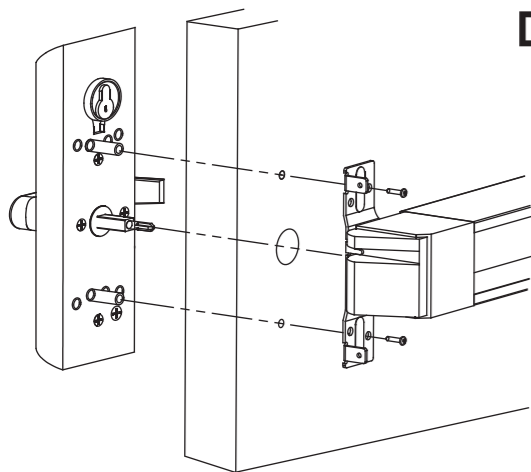
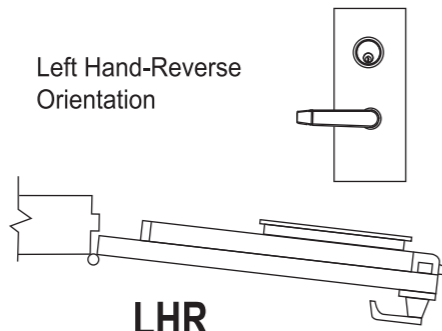

Fig4

Door Handing

Left Hand-Reverse Orientation



LHR

(Left hand reverse)

Fig5

Right Hand-Reverse Orientation

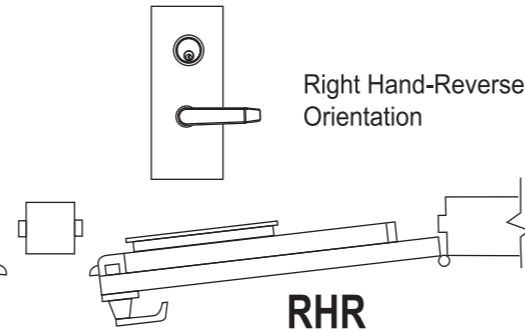

RHR

(Right hand reverse)

Fig6

Instructions for converting Entry to Night latch function

Entry function can be converted to Night latch function by inverting the cam on the mortise cylinder. The steps below show how to invert the cam:

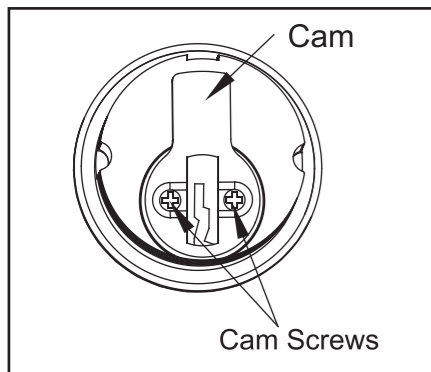

Step # 1:
Locate cam and cam screws on the back of the mortise cylinder.

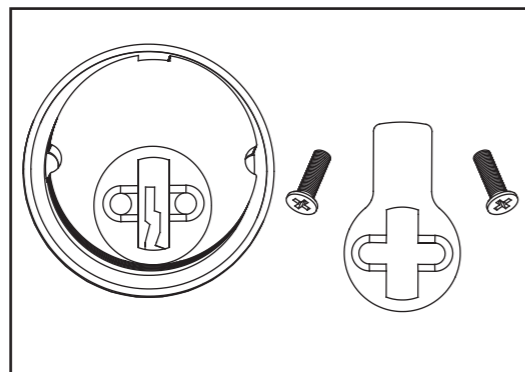

Step # 2:
Remove the two cam screws and the cam.

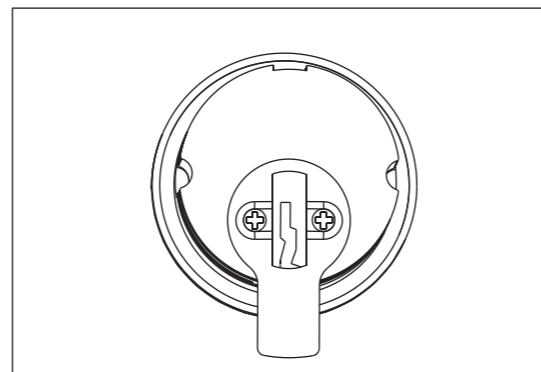

Step # 3:
Rotate cam 180 degrees and re-install in the down position. Re-install and tighten the cam screws being careful not to over tighten them as overtightened screws will make mortise cylinder difficult to operate.
Step # 4:
Follow directions for installing cylinder into trim.

Do not insert the key while converting function.

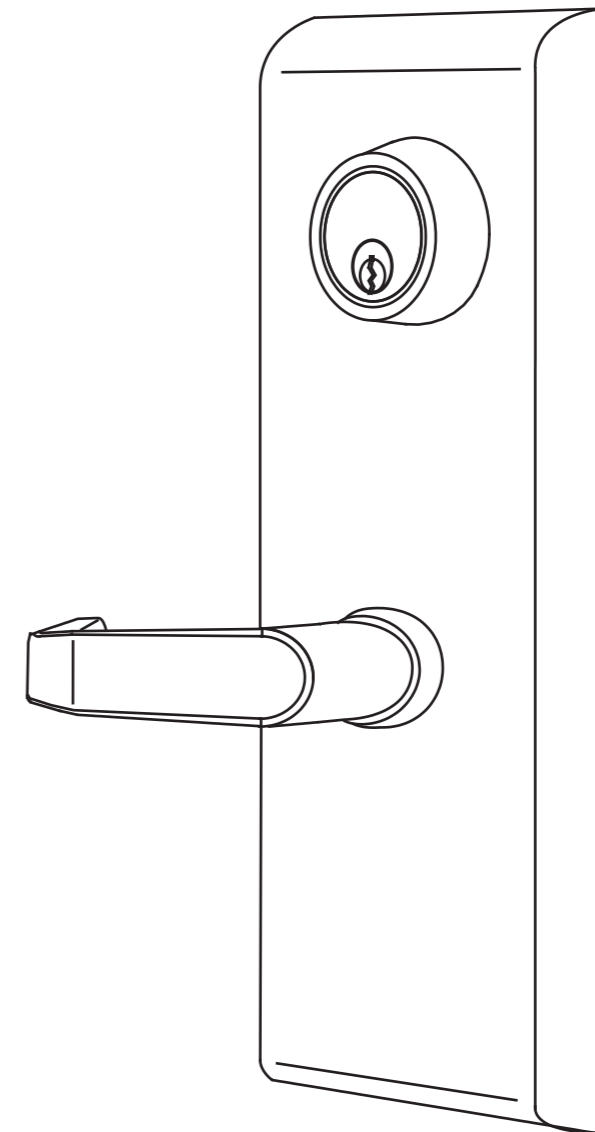

INSTALLATION INSTRUCTIONS

1. DETERMINE HANDING OF DOOR AS LHR OR RHR AND ROTATE LEVER TO CORRESPONDING POSITION. (SEE FIGURE 5 AND 6).
 2. INSERT SCREW A INTO HOLE "A" (SEE FIGURE 2) AND TIGHTEN TO SECURE LEVER POSITION.
 3. INSERT SPINDLE INTO BACK OF LEVER IN HOLE "E". (SEE FIGURE 2).
 4. FOR HEAVY DUTY SERIES SCREWTHRU BOLTS INTO (4) G HOLES & FOR STANDARD SERIES SCREW THRU BOLTS INTO EITHER C&C FOR LHR OR D&D FOR RHR AND TIGHTEN.5. IF CYLINDER IS REQUIRED, INST ALL CYLINDER INTO CYLINDER HOLE WITH CYLINDER COLLAR AND SECURE WITH CYLINDER RETAINING RING RHR AND TIGHTEN.5. IF CYLINDER IS REQUIRED, PUT THE LEVER AT THE REQUIRED LHR OR RHR POSITION , INSERT SCREWS INTO HOLES F&F AND TIGHTEN TO MAKE LEVER RIGID.
 6. IF DUMMY TRIM IS BEING USED , PUT THE LEVER AT THE REQUIRED LHR OR RHR POSITION , INSERT SCREWS INTO HOLES F&F AND TIGHTEN TO MAKE LEVER RIGID.
 7. PROCEED WITH TEMPLATING DOORAS SHOWN IN FIG 7 AND FIG 9 FOR EITHER HEAVY DUTY OR STANDARD SERIES.
 8. INSERT LEVER ESCUTCHEON TRIM INTO DOOR PREP. (SEE FIGURE 3) AND SECURE TO EXIT DEVICE USING MOUNTING SCREWS (SEE FIGURE 4).
- NOTE: DO NOT REMOVE "B" SCREWS (SEE FIGURE 2) OR WARRANTY WILL BE VOID.

For HEAVY DUTY Series-LHR or RHR , drill (4) G holes.

For STANDARD Series ,
If LHR, drill hole C&C.
If RHR, drill hole D&D.

INTERIOR SIDE OF DOOR

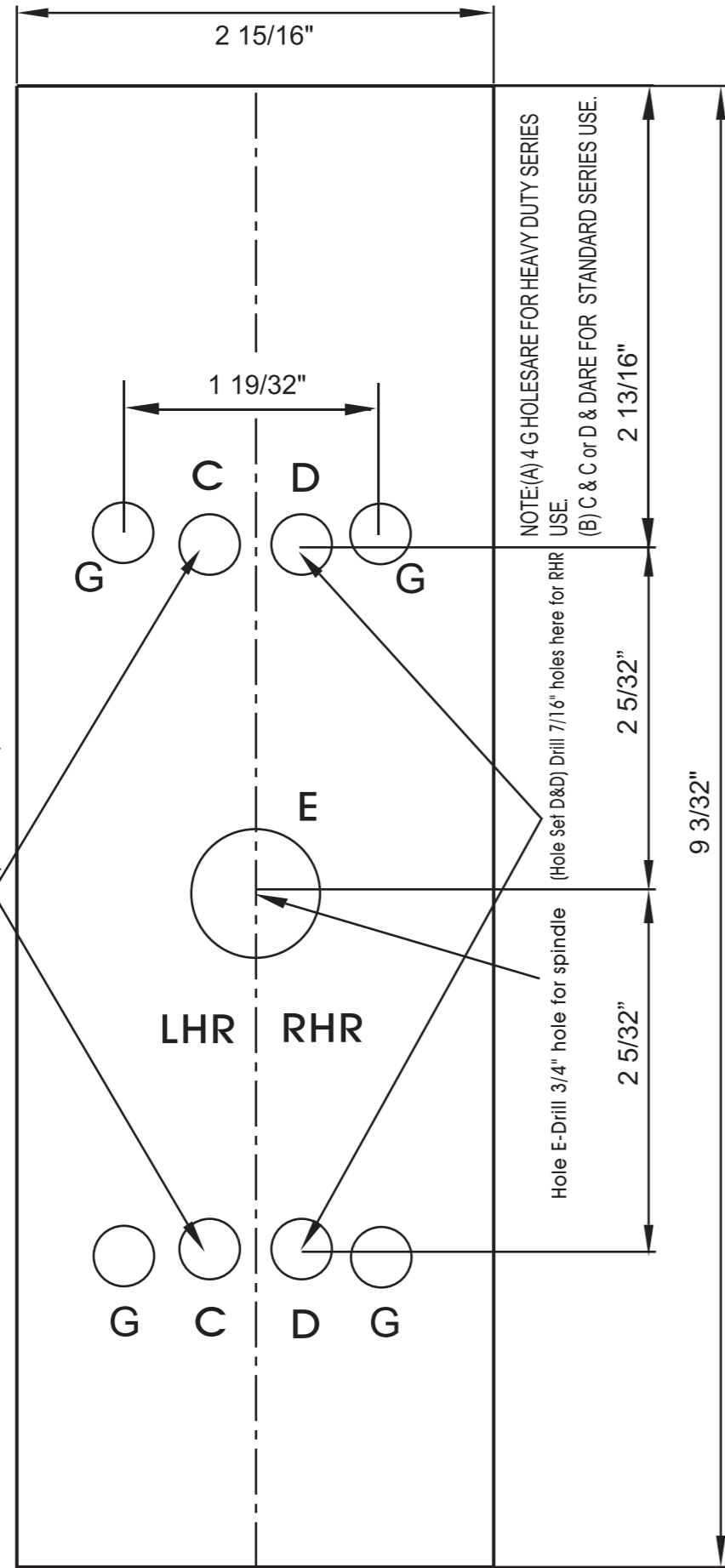

Fig7

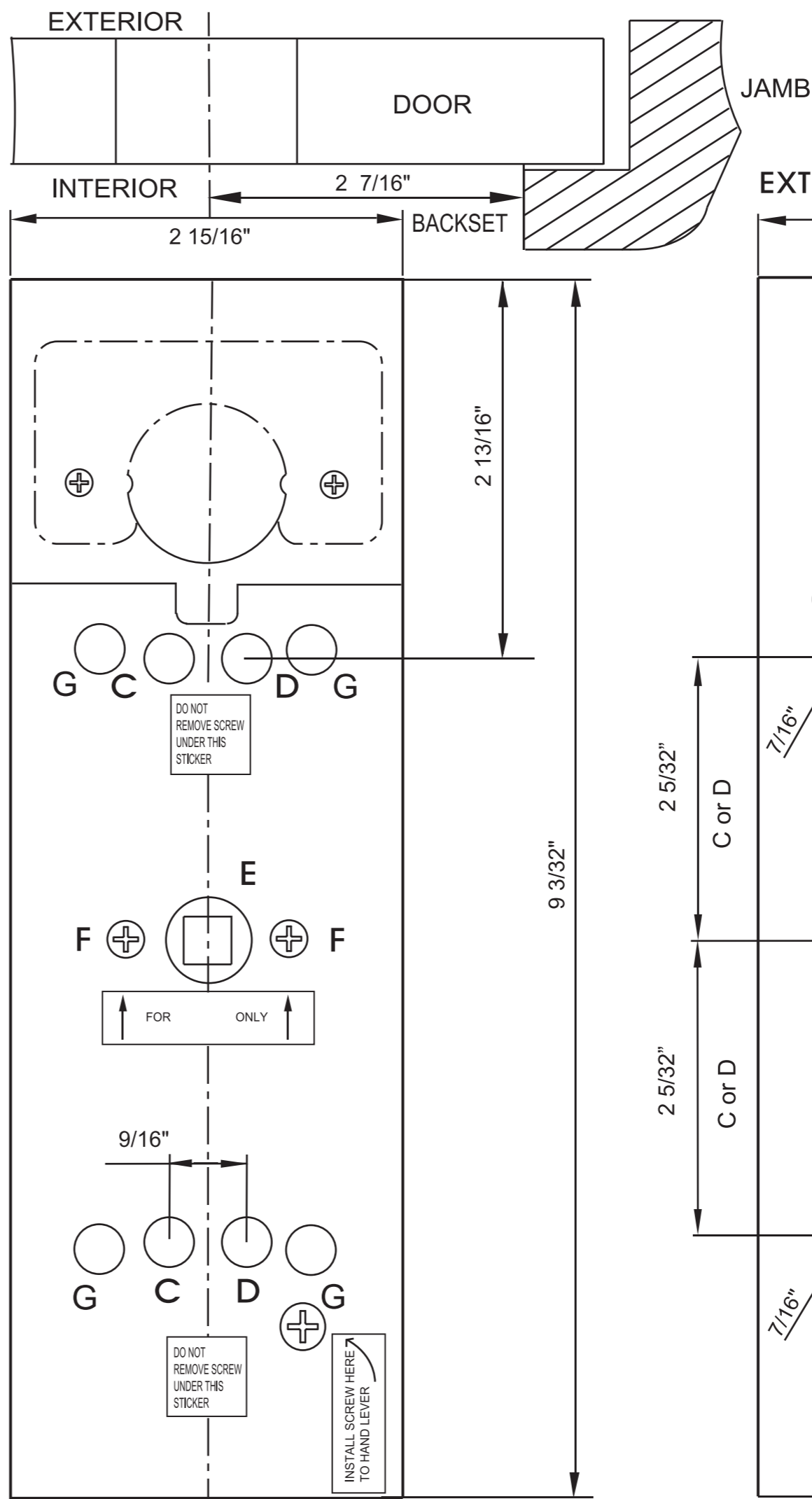

Fig8 BACK OF LEVER TRIM

EXTERIOR SIDE OF DOOR

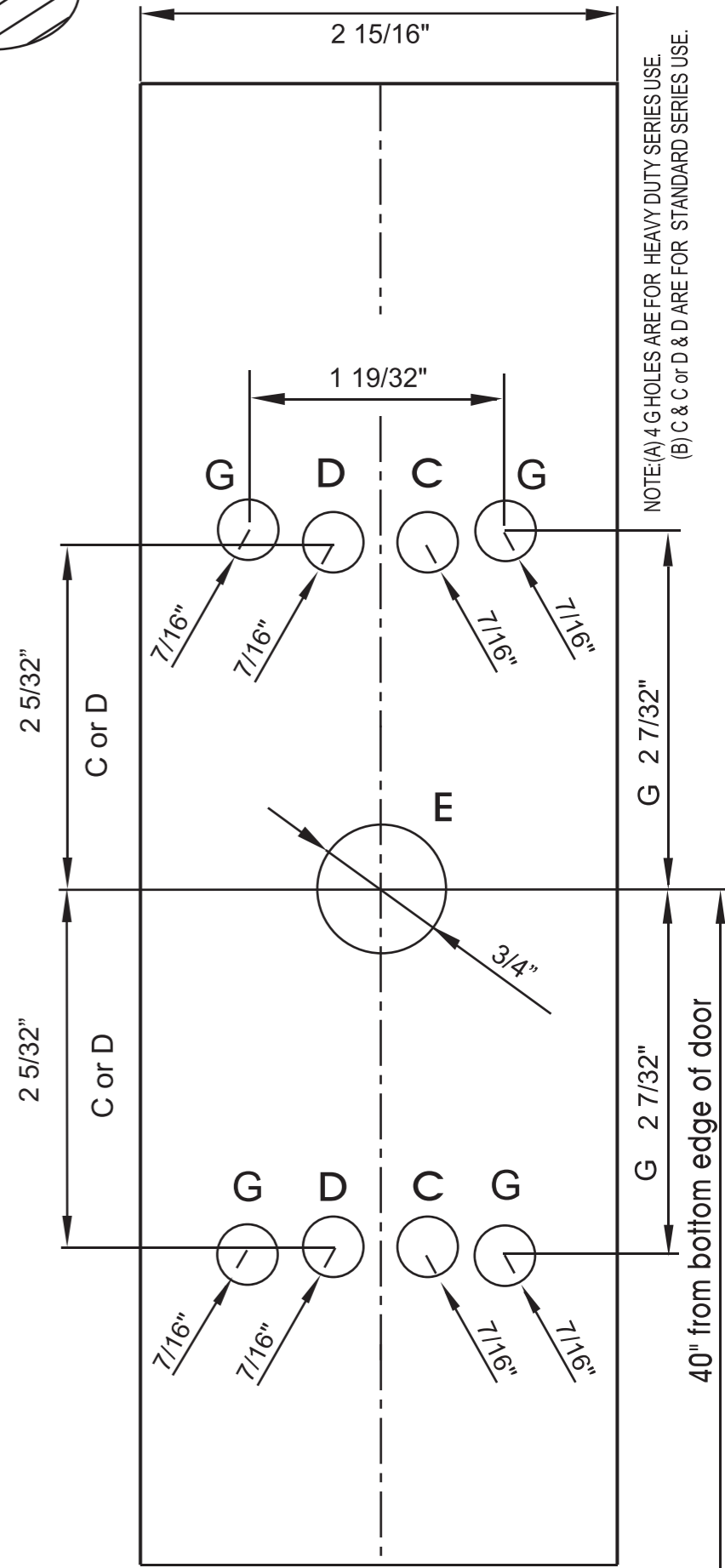

Fig9

NOTE: (A) 4 G HOLES ARE FOR HEAVY DUTY SERIES USE.
(B) C & C OR D & D ARE FOR STANDARD SERIES USE.

40" from bottom edge of door